

MAGNASPHERE HSS INSTALLATION INSTRUCTIONS: All Models of L2C-[XXX]-A-FIRE Series



CAUTION: MAGNASPHERE MAGNET MODULES ARE EXTREMELY POWERFUL. TAKE PRECAUTIONS TO AVOID THE MAGNETIC ATTRACTION OF SHARP TOOLS AND TO AVOID INJURY FROM THE PINCHING FORCE BETWEEN THE MAGNET AND FERROUS METALS OR OTHER MAGNETS.

Attention: modules à aimants Magnasphere et anti-enlèvement aimants sont très puissants: prendre des précautions pour éviter l'attraction magnétique d'outils tranchants et à éviter les blessures de la force de pincement entre l'aimant et les métaux ferreux ou d'autres aimants.

Required Tools and Components

Provided by Manufacturer (per module set)

- 1 L2C-A switch module
- 1 L2C-A magnet module
- 2 #8 screws, switch module
- 2 #8 undercut screws, tamper bracket
- 2 #8 screws, magnet module
- 3 Spacers, magnet module
- 1 Tamper bracket

Provided by Installer

- Phillips screwdriver or a Phillips bit for use in the drill/bit-driver
- Blade screwdriver or a blade bit for use in the drill/bit-driver
- Additional spacers if needed
- Door & frame with cutout (ANSI-style) as prepared in figure below

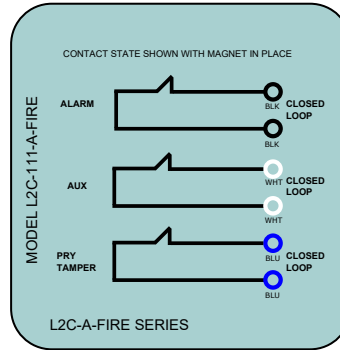
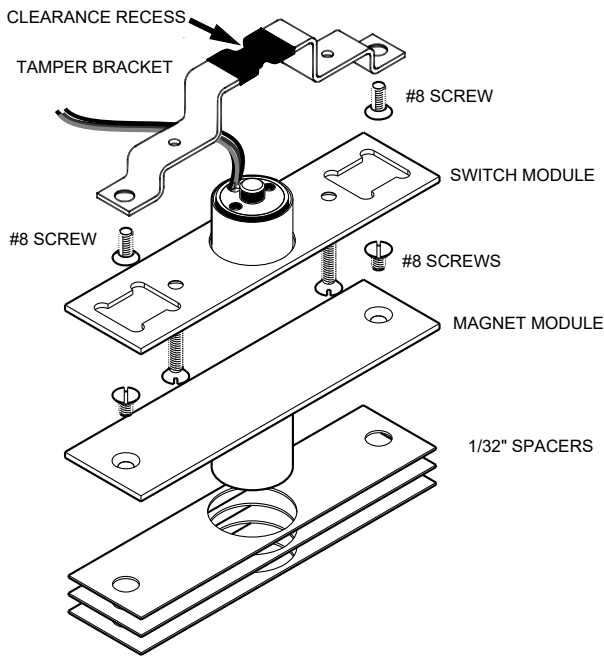

Specifications

Max Current: 0.25 A Resistive

Max Voltage: 30 VDC

Max Power: .25 W Resistive

The Magnasphere L2C-A series is intended to be connected to a UL Listed compatible control panel for US applications and a ULC Listed compatible control panel for Canadian applications.

Gap: 0" to 1/8"

Suitable for outdoor use

UL Classified Miscellaneous Fire Door

Accessory: ANSI/UL 10C Listed, 3 hour rated

LEVEL 2 CONCEALED: High Security contacts for recessed mounting

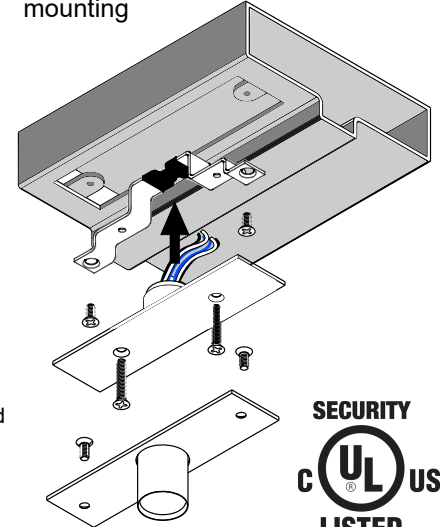

Models having the following infixes are equipped with pry-tampers, a requirement of UL634 High Security Levels 1 and 2: -101-, -111-

Installation:

Recommended Minimum Clearances and Features for Door & Frame Cutouts

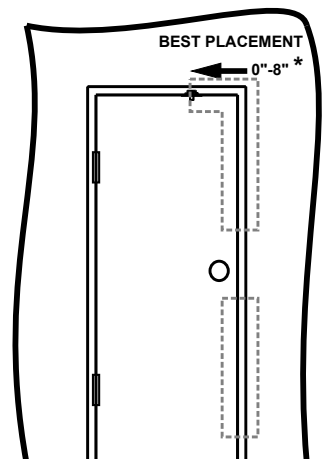
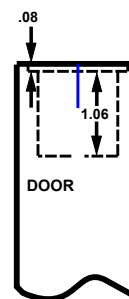
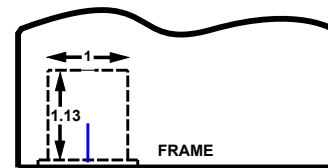
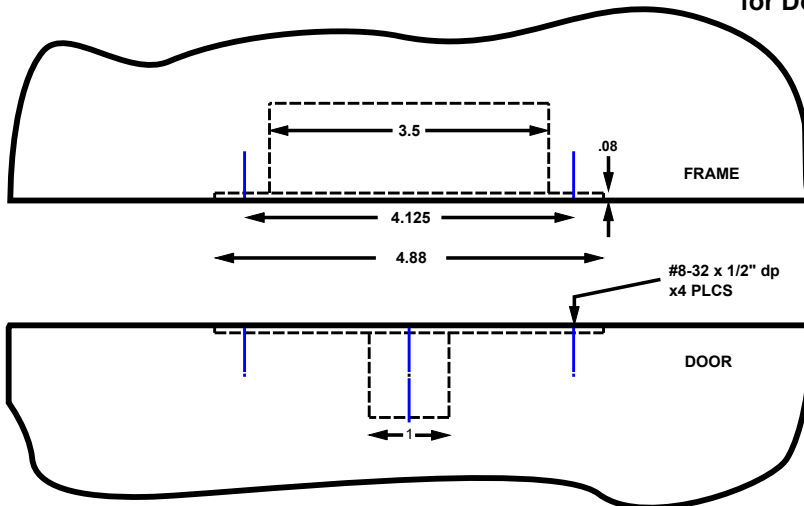

Plan to mount the switch module into the door frame. The magnet module should be mounted opposed and aligned to the switch, within the door. Recommended placement for the set is 8 inches from the latch side of the door, at the top. **A gap no greater than 1/8" (3.17mm) is required for compliance with UL634 Level 2, C634 high security standards.** For UL compliance, the installation must be in a metal frame with a 5/8" (minimum) door stop; the modules must have an operating gap no greater than 1/8".

*Recommended placement to meet door-opening, alarm, & nuisance alarm requirements of UL634 Level 2 standard. This guide is one means to meet this standard. Installations which fulfill this standard are not restricted to the specific recommendations in this instruction set.



(continued) instructions:

The pry tamper (if equipped) can be tested by moving the Tamper Bracket to and from its installed position with the switch module. This tamper will be in alarm condition when the switch module is removed from the tamper bracket 1/16" - 1/4"

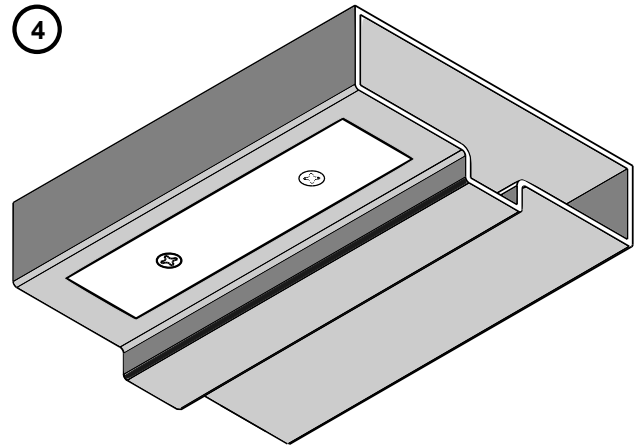
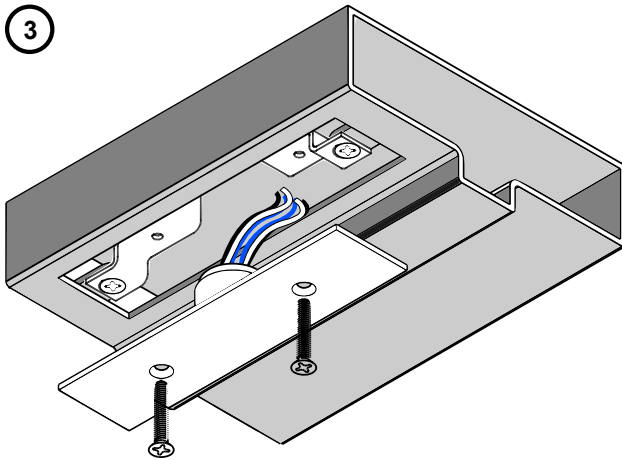
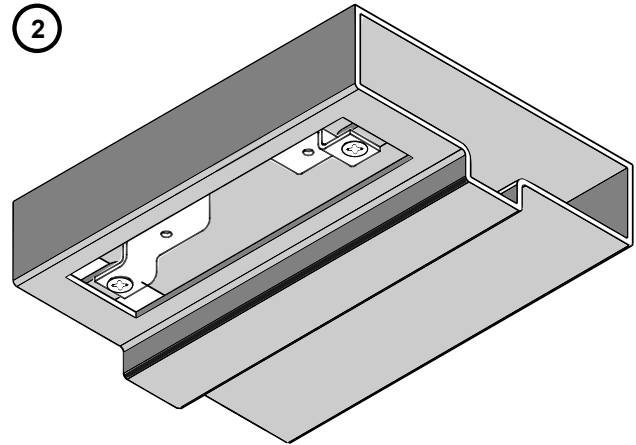
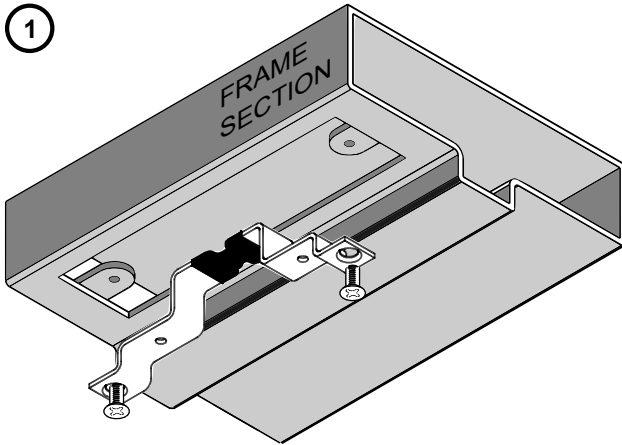
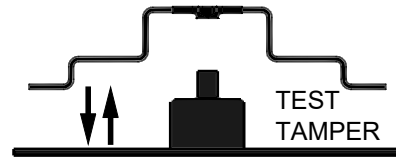

1: Fasten the Tamper Bracket as shown (2), using the undercut #8 screws

3: Plan to orient the switch, allowing the wires to pass along the clearance recess of the tamper bracket. Wire the switch module. The tamper circuit (if equipped) must be wired to a 24-hr protection circuit. All wires must route within the metal frame.

4: Place the switch module into the frame cutout. Ensure that it is fully nested into position. Using hand-tools, drive the screws until seated. Do not use powered tools. Do not over-tighten the screws.

⚠ CAUTION: Magnasphere's magnet module and anti-removal magnet are extremely powerful: Take precautions to avoid the magnetic attraction between the magnet and ferrous metals (or other magnets). **⚠**

Determine whether magnet spacers will be necessary to achieve the operating gap. An operating gap of 0" to 1/8" is required for compliance with UL634 Level 2, C634 high security standard.

5: Fasten the magnet module into the door cutout. The mechanical installation of the set is complete.

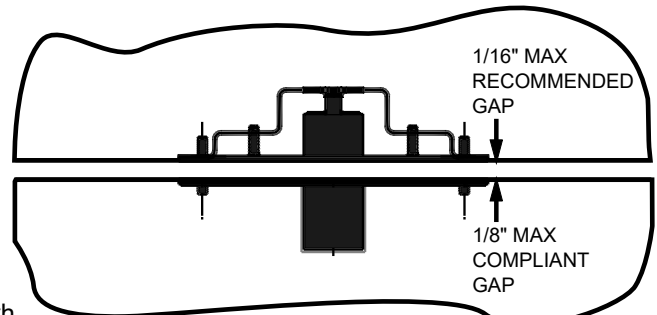

Note: legacy Tamper Bracket has this form and appearance and can serve the same function as those depicted above.

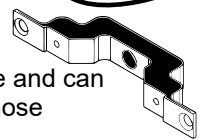

SEP2019 L2C-XXX-A-FIRE INST REV1

Patents #6603378, #7944334, #8487726, #9704680, #9934921, & Patents Pending

MAGNASPHERE®

MAGNASPHERE N22 W22931 Nancys Ct #3 Waukesha, WI 53186 tel 262.347.0711 fax 262.347.0710 www.magnasphere.com